

# ***Hustler Mini Z Bac Vac Parts Manual***



**HUSTLER®**

.....

***Hustler Turf Equipment***

.....

*P.O. Box 7000*

...

*Hesston, Kansas*

.

67062-2097



---

# Table of Contents

## Chapter 1

General Information .....	1
---------------------------	---

## Chapter 2 Contents

Hopper Front Assembly .....	2
Door Assembly .....	4
Hopper Assembly 353219.....	6

## Chapter 3 Contents

Blower Assembly 546416 .....	2
Blower Decals .....	5
Spindle Housing Assembly 520627 .....	6

## Chapter 4 Contents

Blower Installation.....	2
Bac-Vac Installation .....	4
Weight Installation.....	6

Index .....	1
-------------	---



# Chapter 1

## **General Information**

*This Manual covers 379271K (20" tires) & 303842K (23" tires) Hustler Mini Z Bac Vac for 44" Deck, 379289K (20" tires) & 303867K (23" tires) Hustler Mini Z Bac Vac for 52" Deck, 927004 (20" tires) & 927293 (23" tires) (Hustler Mini Z Bac Vac Assembly, 378992 Hustler Mini Z 44" Deck Belt cover Assembly, and 379107 Hustler Mini Z 52" Deck Belt Cover Assembly*

---

## **Service Literature**

<b>PART NO.</b>	<b>DESCRIPTION</b>
379255	Owner's Manual
379263	Parts Manual

---

*Note: When ordering parts, you must use the part number as shown for each part, not the index number. Always give the model and serial number to your parts and service representative.*

*Note: Items sold in bulk such as seals and hoses are sold by the foot.*

---

### **Using this manual**

Illustrations used were current at the time of printing, but subsequent production changes may cause your machine to vary slightly in detail. Excel Industries, Inc. reserves the right to redesign and change the machine as deemed necessary, without notification. If a change has been made to your machine which is not reflected in this parts manual, see your Hustler dealer for current information and parts.

## **Hardware Description Codes & Abbreviations**

The following codes are used throughout this parts manual. Refer to this list when ordering parts.

<b>ABBREVIATION</b>	<b>DESCRIPTION</b>
CB	Carriage Bolt
CE	Clevis Pin
CP	Cotter Pin
CS	Cap Screw
CW	Cup Washer
FDRW	Fender Washer
FW	Flat Washer
HX	Hex Head
LW	Lock Washer
MB	Machine Bushing
MS	Machine Screw
NT	Nut
SC	Self Tapping Cap Screw
SH	Socket Head
SB	Shoulder Bolt
SS	Set Screw
OD	Outside Diameter
ID	Inside Diameter

## **Standard Torques**

The following chart lists the standard torque values for the threaded fasteners found in this manual. Torque all cap screws, nuts and set screws to these values unless a different torque is shown in the Notes section next to the fastener

<b>SIZE</b>	<b>FT-LBS</b>	<b>NM</b>	<b>SIZE</b>	<b>FT-LBS</b>	<b>NM</b>
.250	8.2	11.1	M3	1	1.3
.312	17	23	M4	2.2	3
.375	30	40	M5	4.5	6.1
.438	48	65	M6	7.7	10.4
.500	73	99	M8	18.5	25
.562	105	143	M10	37	50
.625	145	200	M12	64	87
.750	260	350	M16	160	215
.875	420	565	M20	320	435
1.00	625	850	M24	555	750

---

### **NOTE:**

**Lubricate all grease zerks.**

---

## Chapter 2 Contents

Hopper Front Assembly .....	2-2
Door Assembly .....	2-4
Hopper Assembly 353219 .....	2-6

# Hopper Front Assembly

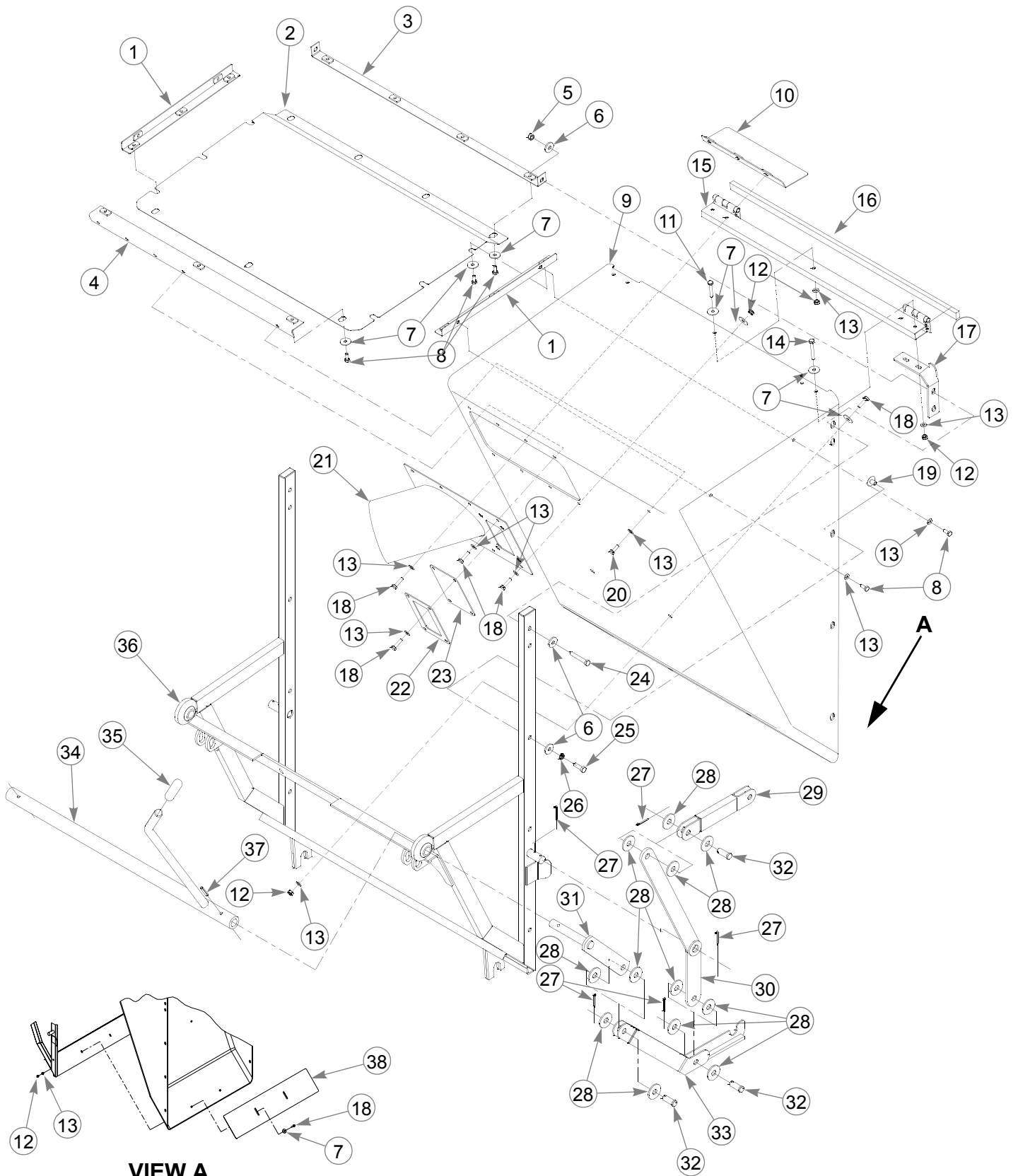



---

## Hopper Front Assembly

INDEX NO.	SERVICE PART NO.	MFG. PART NO.	QTY.	DESCRIPTION
1	300871	300871	2	SIDE MOUNTING SCREEN ANGLE
2	300822	300822	1	HOPPER SCREEN
3	300897	300897	1	HOPPER SCREEN STRAP
4	300863	300863	1	REAR MOUNTING SCREEN ANGLE
5	058776	058776	4	NT .312-18 HX NL ZN
6	712927	712927	14	FW .344 X 1.00 X.12 HRD ZN
7	704304	704304	26	FDW 1.00 X .281 X .06 ZN
8	064329	064329	17	CS .25-20 X .625 HX G5 ZN
9	757278	757278	1	FIBERGLASS HOPPER
10	301119	301119	1	SPOUT DEFLECTOR
11	008581	008581	1	CS .250-20X1.500 HX G5 ZN
12	068551	068551	13	NT .250-20 HX NL ZN
13	017079	017079	26	FW .250X .560X.04 SAE ZN
14	704163	704163	4	CS .250-20 X 2.00 HX G5 ZN
15	300848	300848	1	HINGE
16	737536	737536	1	SEAL .43 X .75 29" LONG
17	499327	499327	1	LH CORNER SUPPORT
	499319	499319	1	RH CORNER SUPPORT
18	056077	056077	16	CS .250-20 X 1.00 HX G5 ZN
19	758789	758789	6	NT .312-18 CAMTAINER FASTNER
20	055939	055939	1	CS .250-20 X .75 HX G5 ZN
21	499426	499426	1	SPOUT
22	301770	301770	1	WINDOW TRIM
23	760512	760512	1	OVERFLOW WINDOW
24	064345	064345	4	CS .312-18 X 2.00 HX G5 ZN
25	036236	036236	6	CS .312-18 X 1.00 HX G5 ZN
26	017004	017004	6	LW .312 MED SPRING ZN
27	011387	011387	10	CP .125D X 1.250 LG HML ZN
28	443549	443549	24	PIVOT BEARING DISC
29	496588	496588	2	DOOR LINKAGE
30	499459	499459	2	DOOR STRAP LINKAGE
31	496554	496554	1	LH PIVOT LINKAGE
	496547	496547	1	RH PIVOT LINKAGE
32	027714	027714	6	CE .500 X 1.25 .156 X 1.093 ZN
33	496570	496570	1	LH DOOR LATCH LINKAGE
	496562	496562	1	RH DOOR LATCH LINKAGE
34	347765	347765	1	HANDLE
35	758854	758854	1	UV .75 ID X 5" LG BLACK GRIP
36	496513	496513	1	BAC VAC FRAME
37	758631	758631	2	RP .250 X 1.375 HEAVY SPIRAL
38	374843	374843	1	CLOSE OUT PLATE

---

### NOTES:

# Door Assembly

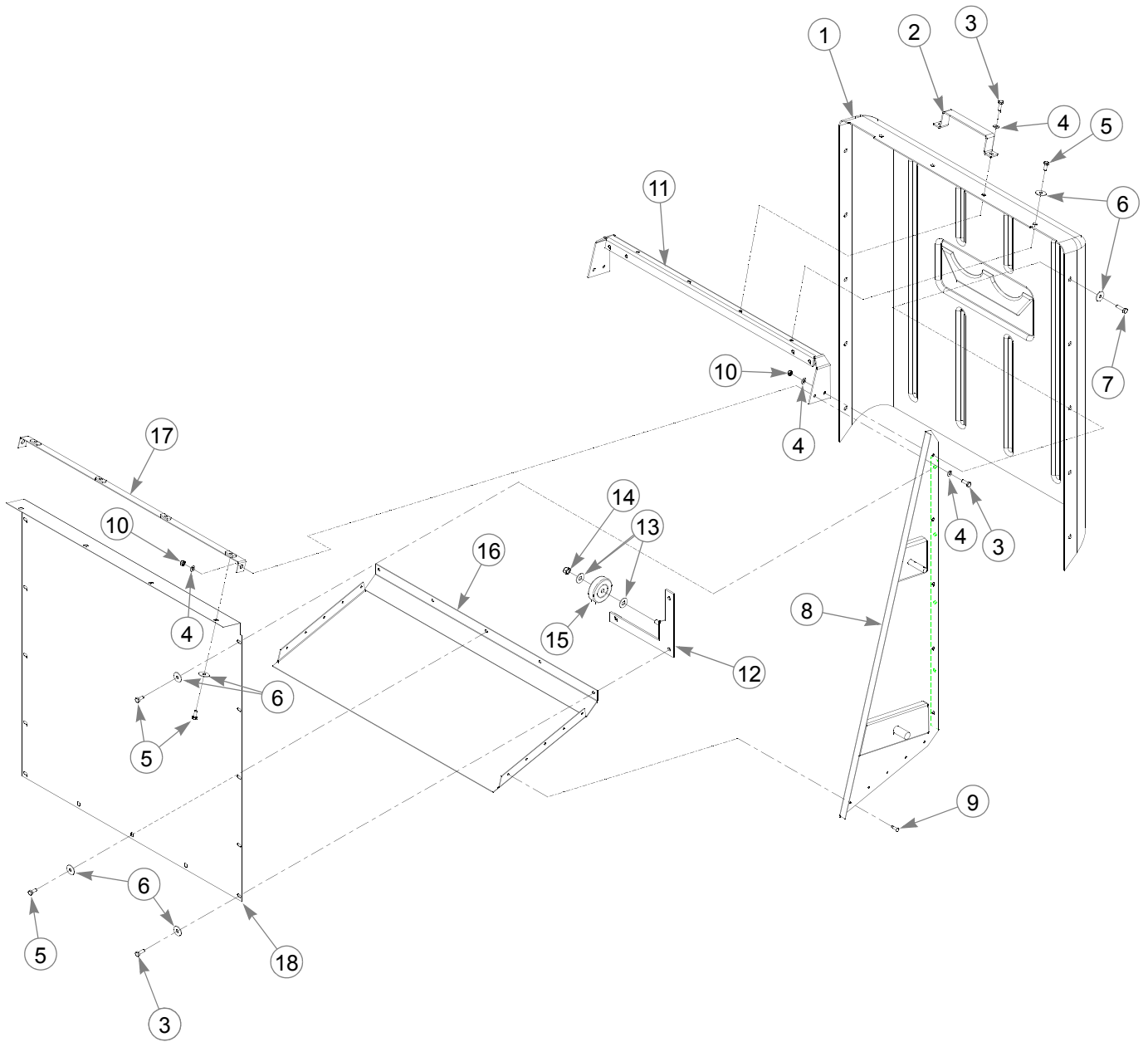

---

## **Door Assembly**

<b>INDEX NO.</b>	<b>SERVICE PART NO.</b>	<b>MFG. PART NO.</b>	<b>QTY.</b>	<b>DESCRIPTION</b>
1	496232	496232	1	REAR DOOR COVER
2	301101	301101	1	HANDLE
3	055939	055939	10	CS .250-20 X .750 H X G5 ZN
4	017079	017079	8	FW .250 X .560 X .04 SAE ZN
5	064329	064329	21	CS .250-20 X .625 HX G5 ZN
6	704304	704304	29	FDW 1.000 X .281 X .06 ZN
7	056077	056077	2	CS .250-20 X1.000 HX G5 ZN
8	499301	499301	1	LH DOOR
	499293	499293	1	RH DOOR
9	760140	760140	10	RIVET .187 X .375 X .375 HD DIA
10	068551	068551	4	NT .250-20 HX NL ZN
11	499400	499400	1	DOOR CHANNEL
12	301036	301036	1	LH WHEEL BRACKET
	301028	301028	1	RH WHEEL BRACKET
13	076422	076422	4	FW .406 X 1.000 X .06 ZN
14	086660	086660	2	NT .375-16 HX LK NY
15	760181	760181	2	2.5X.75 3/8 BORE GRAY WHEEL
16	300855	300855	1	BOTTOM PLATE
17	300889	300889	1	DOOR SCREEN STRAP
18	300814	300814	1	DOOR SCREEN

---

### **NOTES:**

# Hopper Assembly 353219

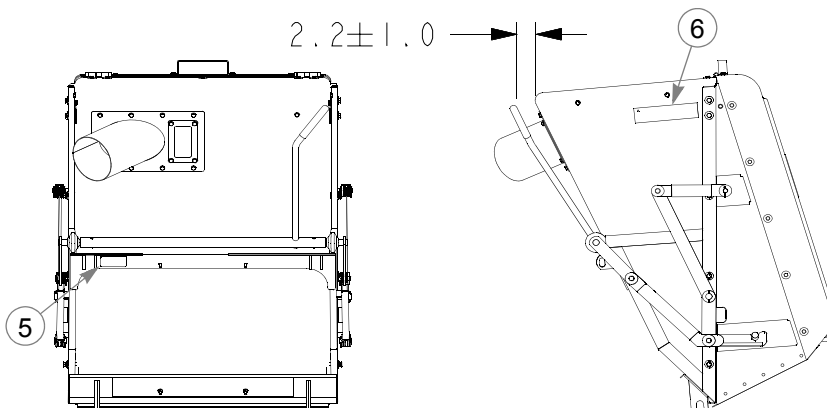
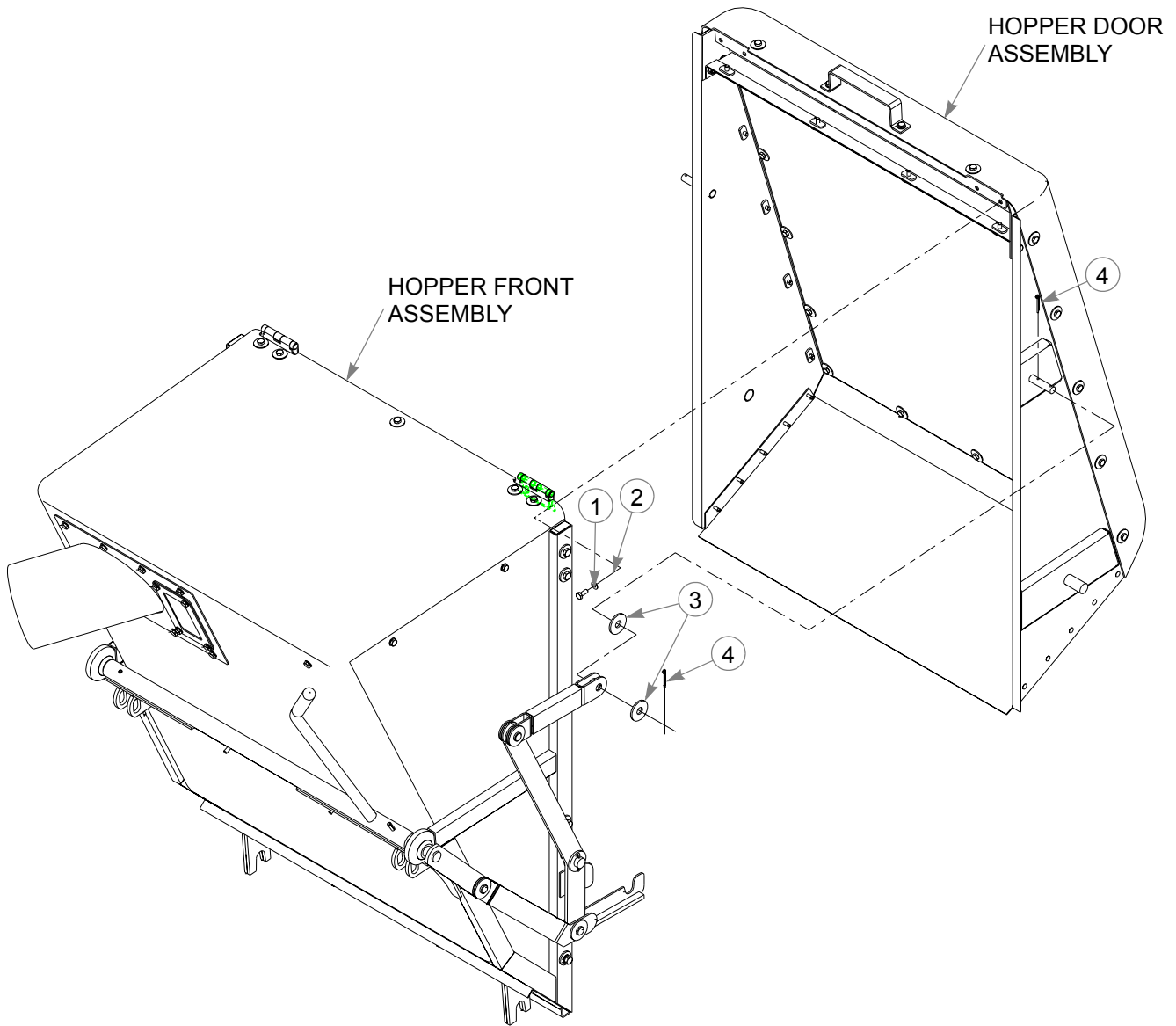

---

# **Hopper Assembly 353219**

<b>INDEX NO.</b>	<b>SERVICE PART NO.</b>	<b>MFG. PART NO.</b>	<b>QTY.</b>	<b>DESCRIPTION</b>
1	064329	064329	4	CS .250-20 X .625 HX G5 ZN
2	017079	017079	4	FW .250 X .560 X.04 SAE ZN
3	443549	443549	4	PIVOT BEARING DISC
4	011387	011387	4	CP .125D X 1.250 LG HML ZN
5	741264	741264	1	MADE IN U.S.A.-COMBO DECAL
6	758532	758532	2	BAC VAC ID DECAL

---

**NOTES:**



---

## Chapter 3 Contents

Blower Assembly 546416 .....	3-2
Blower Decals .....	3-5
Spindle Assembly 520627 .....	3-6

# Blower Assembly 546416

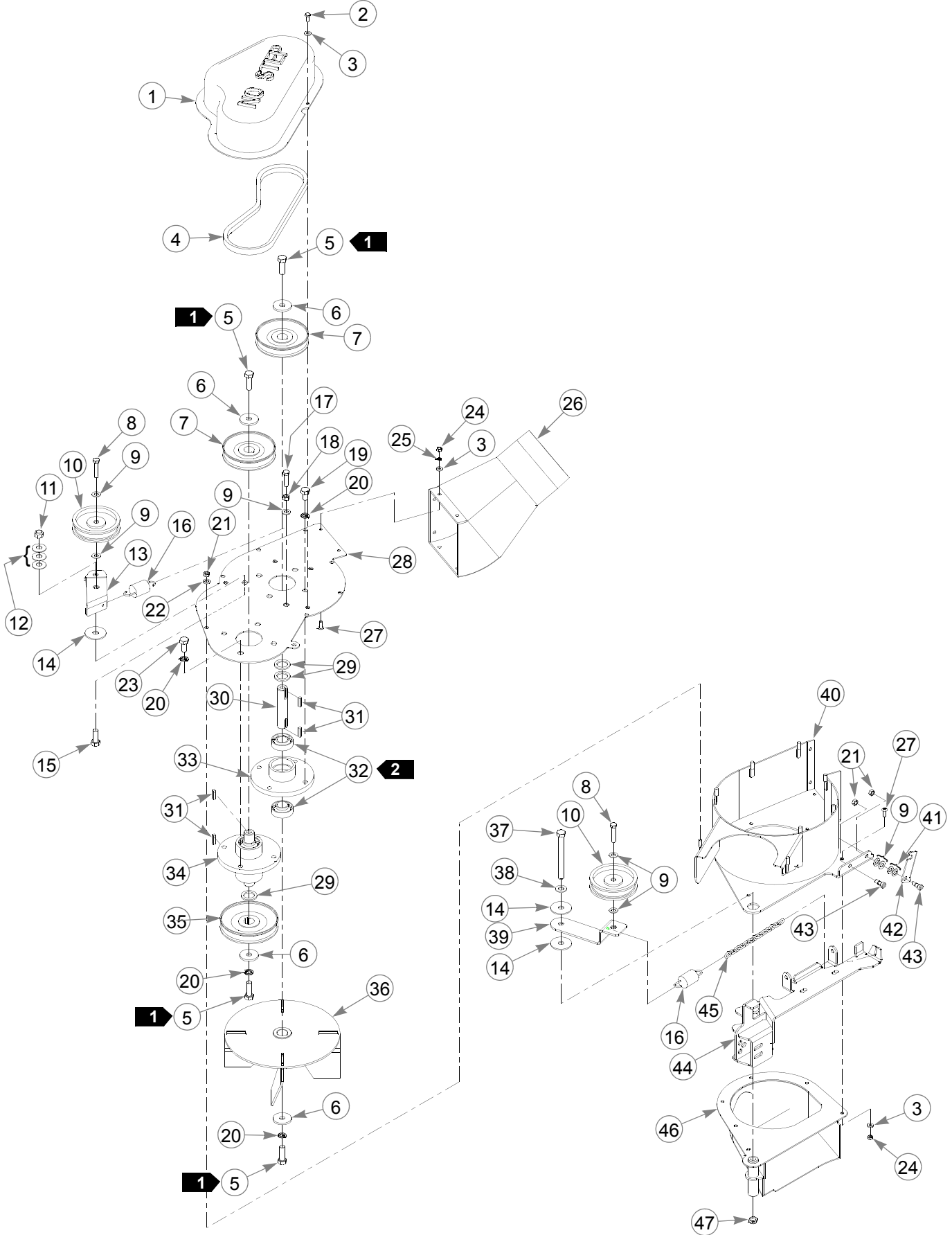



# **Blower Assembly 546416**

ITEM NO.	SERVICE PART NO.	MFG. PART NO.	QTY	DESCRIPTION
1	770180	770180	1	SD DECK BLOWER BELT COVER
2	064329	064329	4	CS .250-20 X .625 HX G5 ZN
3	768515	768515	16	FW .281 X .625 X .051/.080 HD ZN/YL
4	770404	770404	1	UPPER BLOWER BELT
5	078378	078378	4	CS .500-20 X 1.500 HX G5 ZN
6	078386	078386	4	FW .510 X 1.750 X .18 ZN
7	301267	301267	2	5" PULLEY
8	705178	705178	2	CS .375-16 X 1.750 HX G5 ZN
9	767954	767954	7	FW .406 X .812 X .060 SAE HD ZN
10	022772	022772	2	4.00" O.D IDLER PULLEY
11	023317	023317	1	NT .500-13 UNT LK G5 ZN
12	068759	068759	3	CW .560 X 1.340 X .05 PN
13	376921	376921	1	SECONDARY IDLER
14	263517	263517	3	BEARING DISC
15	074252	074252	1	CS .500-13 X 1.50 HX G5 ZNYC
16	036384	036384	2	SPRING
17	005116	005116	1	CS .375-16 X 1.375 HX G5 ZNYC
18	054502	054502	1	NT .375-16 HX GRD 5 ZNYC
19	705194	705194	4	CS .500-13 X .750 HX G5 ZN
20	017046	017046	10	LW .500 MED SPRING ZN
21	034272	034272	10	NT .312-18 HX G5 ZNYC
22	768523	768523	8	FW .343 X .687 X .051/.080 HD ZN/YL
23	016527	016527	4	CS .500-13 X 1.00 HX G5 ZN
24	024927	024927	12	NT .250-20 HX GR.5 ZN
25	017038	017038	6	LW .250 MED SPRING ZN
26	757245	757245	1	TRANSITION CHUTE
27	079194	079194	12	MS .250-20 X .750 TH CR ZN
28	376822	376822	1	BLOWER ROOF
29	045765	045765	3	FW 1.030 X 1.500 X .134 ZN
30	758730	758730	1	FAN SHAFT
31	212472	212472	4	¼" SQ X 1.00" LONG KEY
32	077123	077123	2	BEARING W/O COLLAR
33	022582	022582	1	CAST SPINDLE HOUSING
34	520627	426296	1	SPINDLE HOUSING ASSEMBLY
35	301317	301317	1	PULLEY
36	758565	758565	1	11" IMPELLER
37	051151	051151	1	CS .500-13 X 5.000 HX G5 ZNYC
38	767962	767962	1	FW .531 X 1.063 X .090 SAE HD ZN
39	376897	376897	1	PRIMARY IDLER
40	376277	376277	1	BLOWER HOUSING
41	035188	035188	2	CW .375 X .750 X .04 CUP Z&Y
42	376947	376947	1	BLOWER LATCH
43	754358	754358	2	SB .375 X .375 SH .312-18
44	376046	376046	1	BLOWER MOUNT
45	259812	259812	1	DECK LIFT SPRING CHAIN
46	379180	379180	1	MINI-BLOWER INLET
47	707398	707398	1	NT .500-13 JAM NY LK

---

**NOTES:**

1. Torque bottom bolt to 65 ft. lbs. first then torque top bolt to 65 ft. lbs.
2. Assemble bearings in spindle housing with extended race to the inside.

# Blower Decals

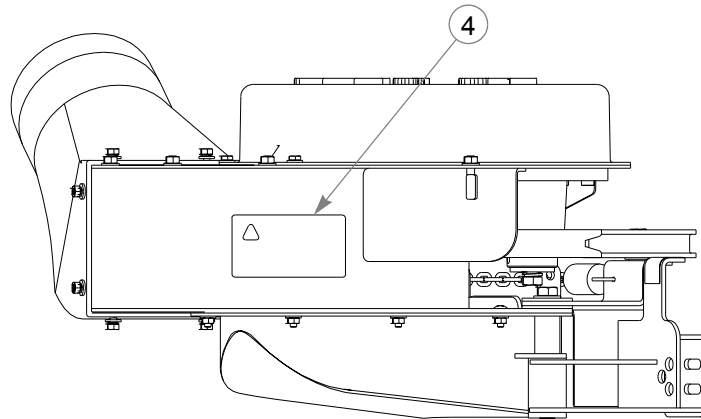
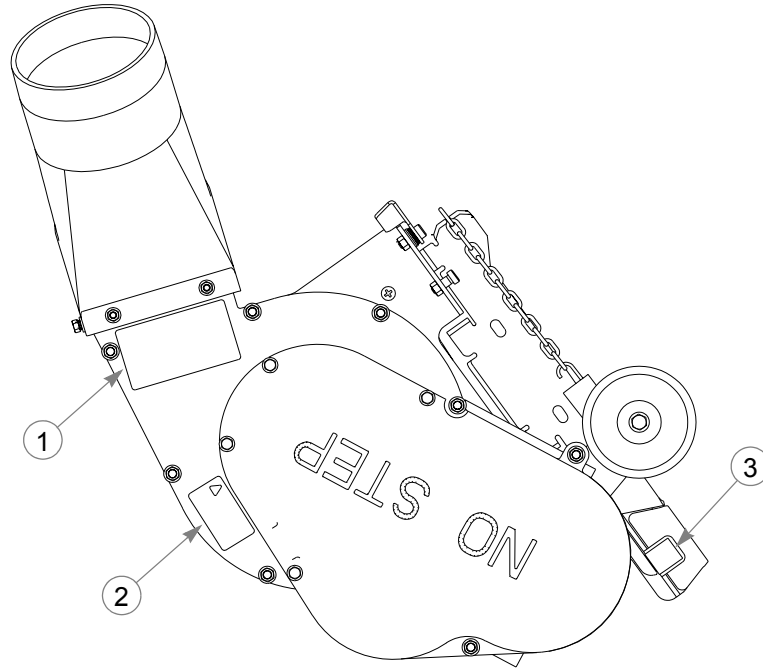

ITEM NO.	SERVICE PART NO.	MFG. PART NO.	QTY	DESCRIPTION
1	767012	767012	1	BLOWER DANGER DECAL
2	727453	727453	1	BELT & PULLEY DECAL
3	722199	722199	1	2" WIDE SCOTCH POLYURETHANE
4	727438	727438	1	WHIRLING BLADES DECAL

## NOTES:

# Spindle Housing Assembly 520627

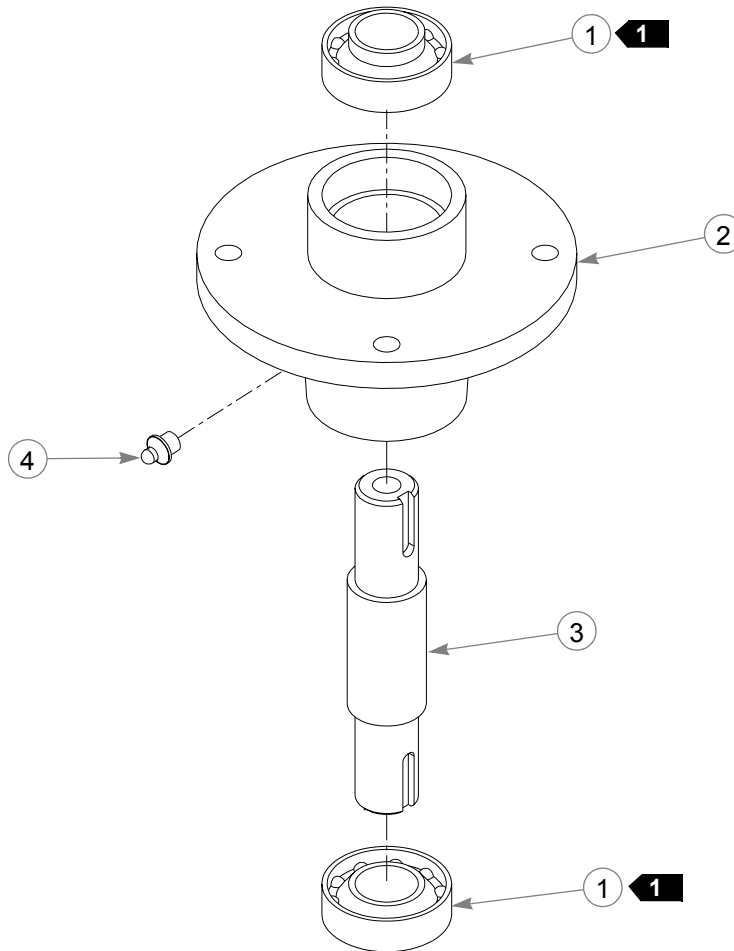

---

ITEM NO.	SERVICE PART NO.	MFG. PART NO.	QTY	DESCRIPTION
1	077123	N/A	2	BEARING W/O COLLAR
2	034843	N/A	1	CAST SPINDLE HOUSING
3	008805	N/A	1	SPINDLE SHAFT
4	012005	N/A	1	GREASE FITTING

---

## NOTES:

1. Install upper bearing with extended inner race up and lower bearing with extended inner race down.

---

## Chapter 4 Contents

Blower Installation . . . . .	4-2
Bac-Vac Installation . . . . .	4-4
Weight Installation . . . . .	4-6

# **Blower Installation**

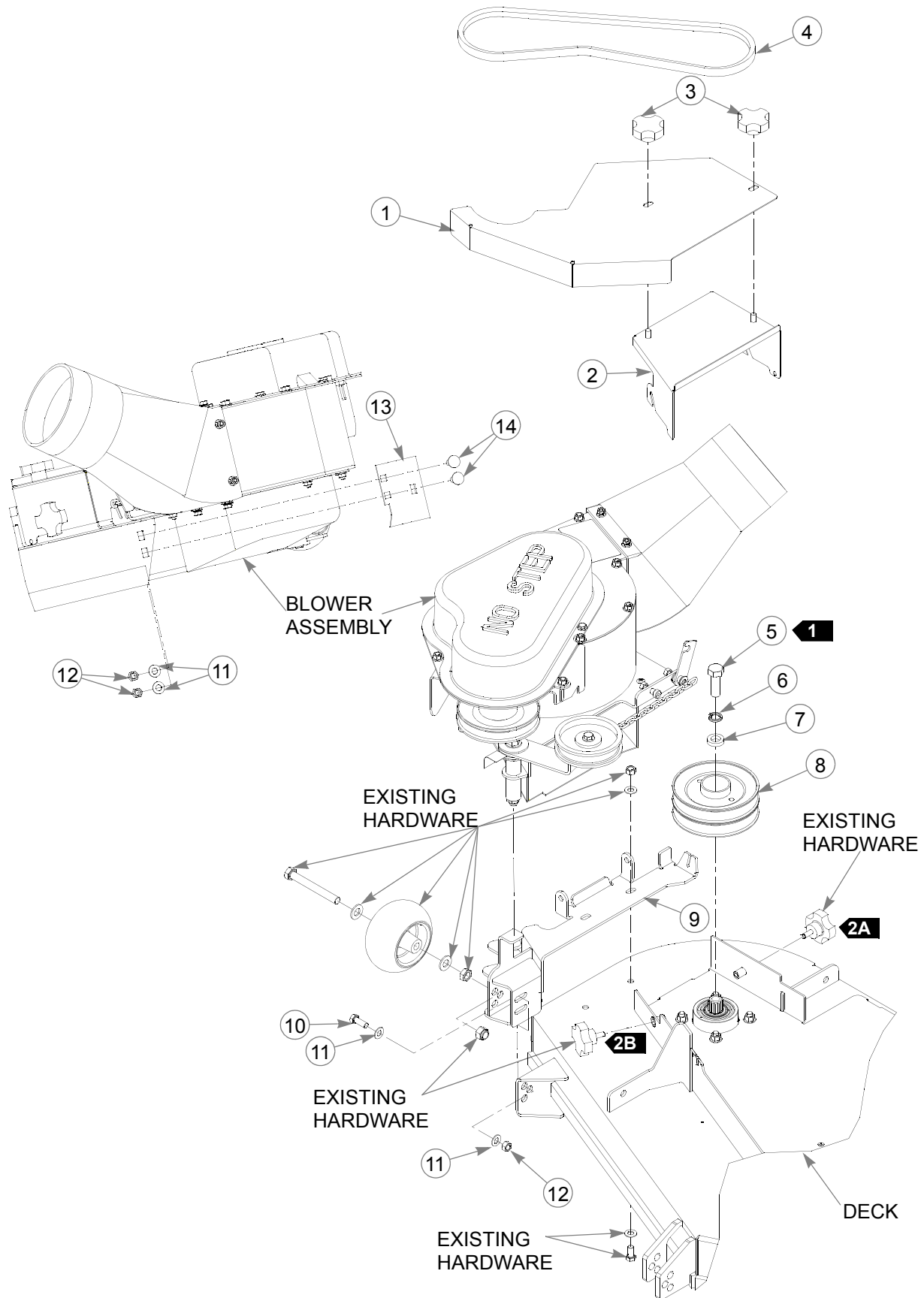

---

## **Blower Installation**

<b>INDEX NO.</b>	<b>SERVICE PART NO.</b>	<b>MFG. PART NO.</b>	<b>QTY.</b>	<b>DESCRIPTION</b>
1	378034	378034	1	52" BELT COVER ATTACHMENT
	378018	378018	1	44" BELT COVER ATTACHMENT
2	376863	376863	1	52" DRIVE BELT COVER
	378232	378232	1	44" DRIVE BELT COVER
3	075291	075291	2	CLAMP KNOB
4	787986	787986	1	52" MINI BLOWER DRIVE BELT
	787978	787978	1	44" MINI BLOWER DRIVE BELT
5	025007	025007	1	CS .625-11 X 1.750 HX G5 ZNYC
6	017053	017053	1	LW .625 MED SPRING ZNYC
7	769257	769257	1	FW .656 X 1.250 X .250 ZNYC
8	787853	787853	1	5.25 EOD DECK DRIVE PULLEY
9	376046	N/A	1	BLOWER MOUNT
10	036244	036244	2	CS .375-16 X 1.000 HX G5 ZNYC
11	767954	767954	6	FW .406 X .812 X .060 SAE HD ZN
12	054502	054502	4	NT .375-16 HX GRD 5 ZN
13	102806	102806	1	DISCHARGE ADAPTER PLATE
14	025395	025395	2	CB .375-16X 1.00 STD CD

---

### **NOTES:**

1. Torque to 65-75 ft. lbs.
2. For decks with studs in place of rivet nuts, order the following parts:

### **SERVICE PARTS**

2A	075291
2B	774497

# **Bac-Vac Installation**

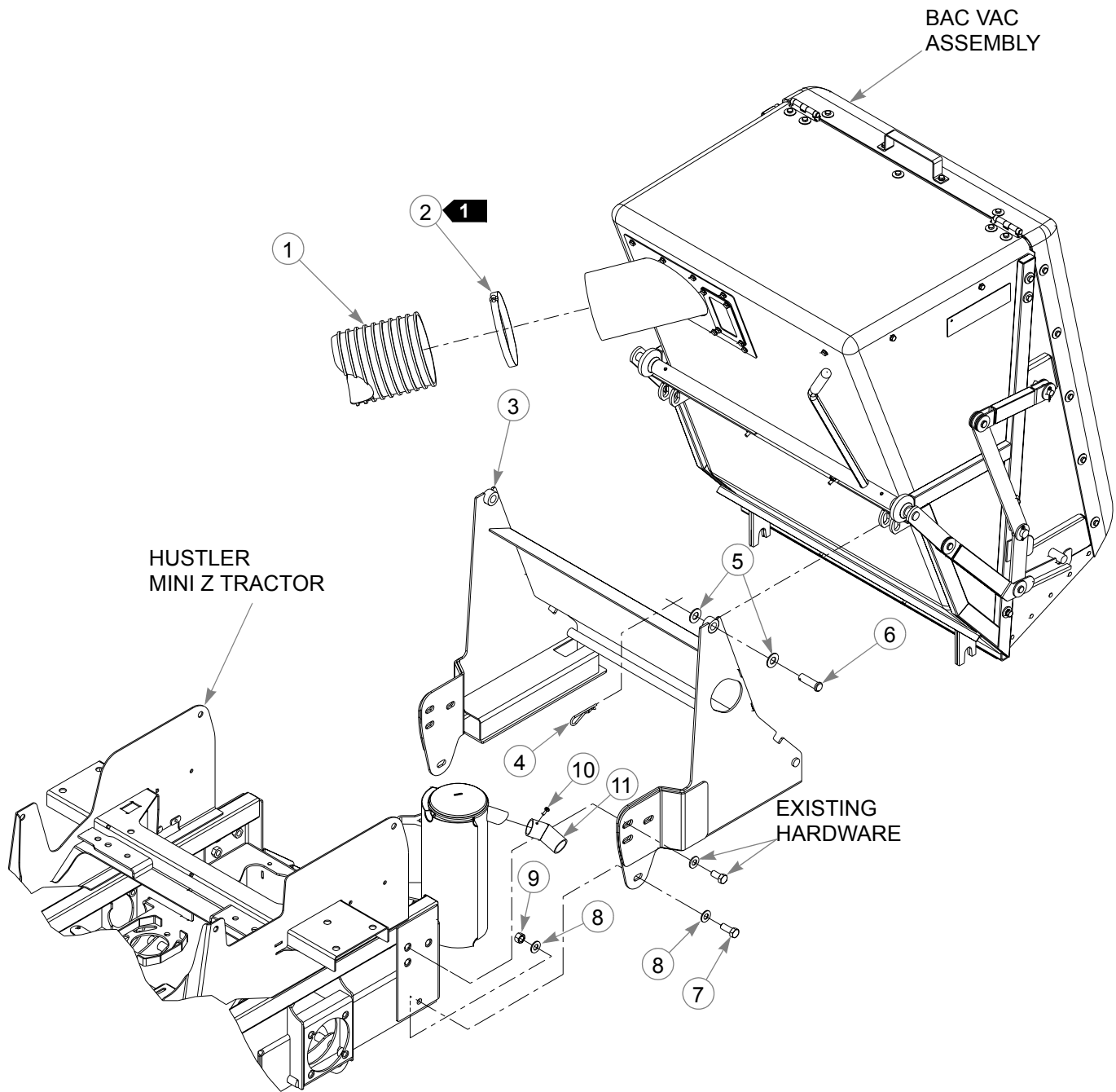



---

## **Bac-Vac Installation**

<b>INDEX NO.</b>	<b>SERVICE PART NO.</b>	<b>MFG. PART NO.</b>	<b>QTY.</b>	<b>DESCRIPTION</b>
1	788075	788075	1	FLEXIBLE TRANSFER TUBE (USED ON 927004)
	760306	760306	1	FLEXIBLE TRANSFER TUBE (USED ON 927293)
2	022608	022608	2	HOSE CLAMP
3	373761	373761	1	MINI Z BAC VAC MOUNT (USED ON 927004)
	399915	399915	1	MINI Z 23" BAC VAC MOUNT (USED ON 927293)
4	023036	023036	2	HP .148 X 2.690 ZN
5	728030	728030	4	FW .656 X 1.312 X .090 ZN
6	063560	063560	2	CE .625 X 2.00 .156 X 1.84 ZN
7	705954	705954	2	CS .500-13 X 1.25 HX G5 ZNYC
8	767962	767962	4	FW .531 X 1.063 X .090 SAE HD ZN
9	008193	008193	2	NT .500-13 HX G5 ZNYC
10	769299	769299	1	SC #10 X.750 PHILLIPS TYAB ZN
11	379420	379420	1	MINI-Z TAIL PIPE EXTENSION

---

### **NOTES:**

1. Second clamp is installed on Flexible Transfer Tube at Blower Outlet.

# Weight Installation

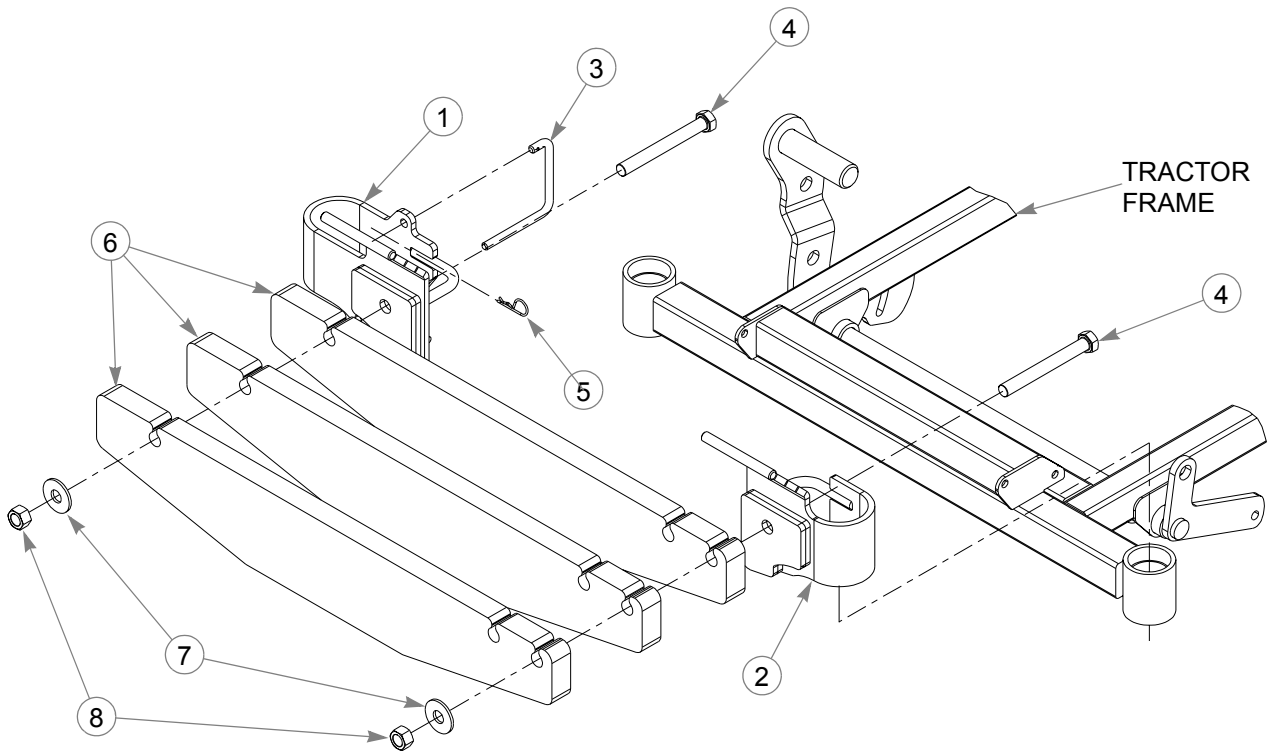

INDEX NO.	SERVICE PART NO.	MFG. PART NO.	QTY.	DESCRIPTION
1	378836	378836	1	R.S. CATCHER WEIGHT MOUNT
2	378786	378786	1	L.S. CATCHER WEIGHT MOUNT
3	378869	378869	1	CATCHER MOUNT PIN
4	005207	005207	2	CS .625-11 X 5.500 HX G5
5	025320	025320	1	HP .091 X 1.870 ZN
6	304204	304204	3	WEIGHT
7	017152	017152	2	FW .680 X 1.750 X .14 SAE ZNYC
8	016972	016972	2	NT .625-11 HX G5 ZNYC

## NOTES:

# Numerical Index

Part No.	Page No.	Part No.	Page No.	Part No.	Page No.
<b>Index</b>					
Numerics		212472	3	496562	3
005116	3	259812	3	496570	3
005207	6	263517	3	496588	3
008193	5	300814	5	499293	5
008581	3	300822	3	499301	5
008805	6	300848	3	499319	3
011387	3, 7	300855	5	499327	3
012005	6	300863	3	499400	5
016527	3	300871	3	499426	3
016972	6	300889	5	499459	3
017004	3	300897	3	520627	3
017038	3	301028	5	546416	2, 3
017046	3	301036	5	704163	3
017053	3	301101	5	704304	3, 5
017079	3, 5, 7	301119	3	705178	3
017152	6	301267	3	705194	3
022582	3	301317	3	705954	5
022608	5	301770	3	707398	3
022772	3	303842K	1	712927	3
023036	5	303867K	1	722199	5
023317	3	304204	6	727438	5
024927	3	347765	3	727453	5
025007	3	353219	6, 7	728030	5
025320	6	373761	5	737536	3
025395	3	374843	3	741264	7
027714	3	376046	3	754358	3
034272	3	376277	3	757245	3
034843	6	376822	3	757278	3
035188	3	376863	3	758532	7
036236	3	376897	3	758565	3
036244	3	376921	3	758631	3
036384	3	376947	3	758730	3
045765	3	378018	3	758789	3
051151	3	378034	3	758854	3
054502	3	378232	3	760140	5
055939	3, 5	378786	6	760181	5
056077	3, 5	378836	6	760306	5
058776	3	378869	6	760512	3
063560	5	378992	1	767012	5
064329	3, 5, 7, 3	379107	1	767954	3
064345	3	379180	3	767962	3, 5
068551	3, 5	379255	1	768515	3
068759	3	379263	1	768523	3
074252	3	379271K	1	769257	3
075291	3	379289K	1	769299	5
076422	5	379420	5	770180	3
077123	3, 6	399915	5	770404	3
078378	3	443549	3, 7	787853	3
078386	3	496232	5	787978	3
079194	3	496513	3	787986	3
086660	5	496547	3	788075	5
102806	3	496554	3	927004	1

Part No.	Page No.	Part No.	Page No.	Part No.	Page No.
927293	1				